

快速虎鉗
QUICK JAW VISE

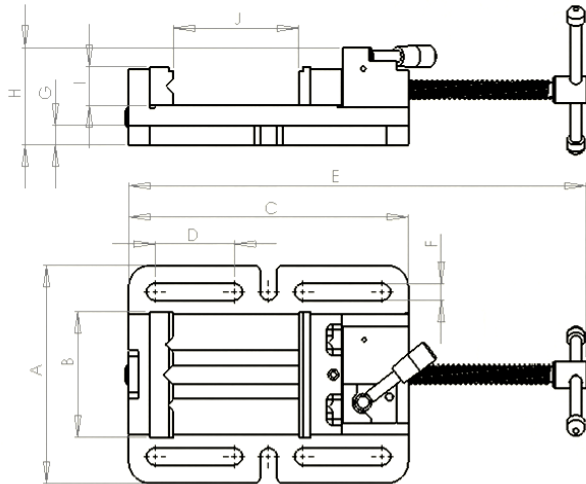
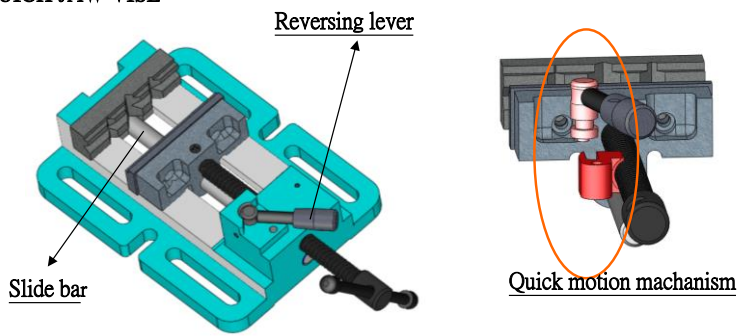

Feature:

- Suitable for clamping work piece on drill press machine or milling machine
- Quick motion mechanism design makes clamping and releasing work piece promptly by swiveling the reversing lever.
- Slide bar design makes work piece is firmly fixed by jaw pair without any inclined situation of the jaws
- Designed with solid structure, main body is made of FC15, assemble a pair of heat treated steel jaws with hardness HRC 45°~50°
- Jaw pair and handle are surface treated by black oxide finish
- Front fixed prismatic jaw with cross V-grooves is designed for clamping work piece firmly in both vertical & horizontal directions.

Unit: mm

Order No.	A	B	C	D	E	F	G	H	I	J(Min.)	Max. clamping force (ton)	weight
103-3	155	83	213	66.5	345	13.5	15	60	32	78	0.8	4.9
103-4	180	104	235	69.5	390	14	16.5	73	32	105	1.0	6.5
103-6	240	156	310	85	530	17	18	93	38	152	1.8	12.2