

三面虎鉗
3 WAY VISE

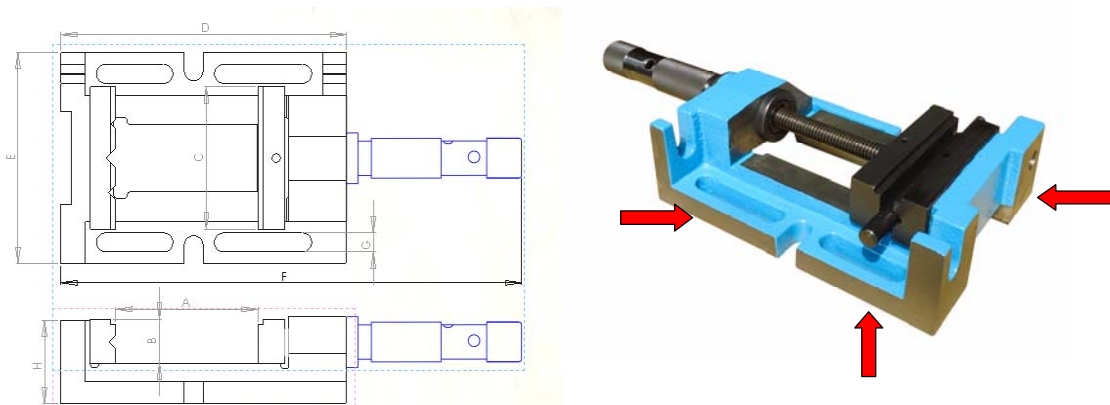

Feature:

- 3 dimension processed surfaces are applicable for clamping work piece on drill press machine & milling machine
- Designed with solid structure, main body is made of FCD45, assemble a pair of heat treated steel jaws with hardness HRC 45°~50°
- Jaw pair and handle are surface treated by black oxide finish
- Front fixed prismatic jaw with cross V-grooves is designed for clamping work piece firmly in both vertical & horizontal directions.
- The verticality tolerance between each 2 surfaces of 3 dimensions are controlled in 0.100 mm

Order No.	A	B	C	D	E	F	G	H	Max. clamping force (ton)	weight
107-4	101	32	104	209	156	340	12	62	1.6	5.9