

聯結螺帽  
**COUPLING NUT**

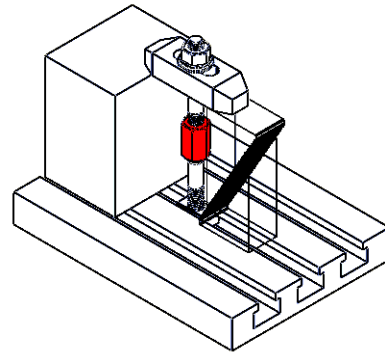
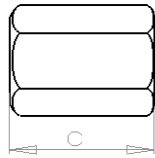
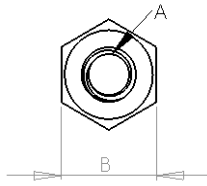

- ※ Material: S45C
- ※ Hardness of heat treatment : HRC32±5°
- ※ Surface treatment: black oxide furnished
- ※ Connect two studs on both ends of nut to extend the length of applying range

Unit: mm

Order no.	A (Metric)	B	C
CNM-32021	M8X1.25	13	22
CNM-33031	M10X1.5	17	25
CNM-34041	M12X1.75	21	32
CNM-34545	M14X2.0	21	32
CNM-35051	M16X2.0	26	40
CNM-36061	M18X2.5	32	48
CNM-37071	M20X2.5	32	48
CNM-38081	M24X3.0	41	63

Order no.	A (Inch)	B	C
CN-33031	3/8"-16	17	25
CN-34041	1/2"-12	21	32
CN-34042	1/2"-13UNC	21	32
CN-35051	5/8"-11	26	40
CN-36061	3/4"-10	32	48
CN-37071	7/8"-9	36	48
CN-38081	1"-8	41	63