

三角級枕  
STEP BLOCK

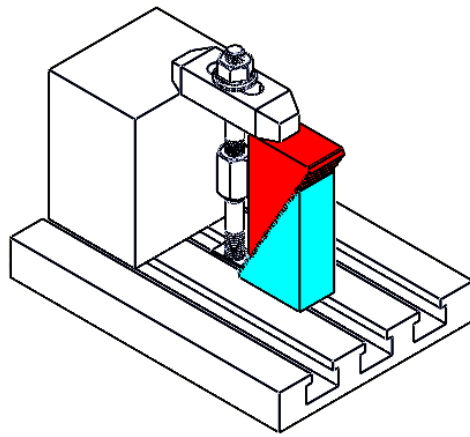
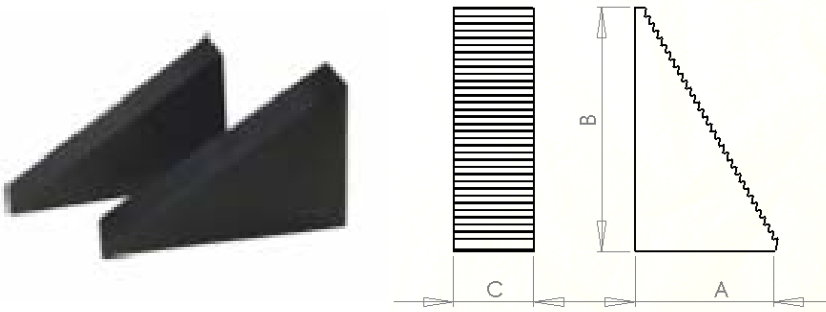

- ※ Material: S45C
- ※ Hardness of heat treatment : HRC32±5°
- ※ Surface treatment: black oxidefurnished
- ※ The height of block is adjustable when stack up a pair of step block

Unit: mm

Order no.	Model	A	B	C
SB-53031	3/8 (S)	19	30	25
SB-53032	3/8 (M)	29	47	25
SB-53033	3/8 (L)	59	97	25
SB-54041	1/2 (S)	19	30	32
SB-54042	1/2 (M)	27	45	32
SB-54043	1/2 (L)	59	97	32
SB-56061	3/4 (S)	38	59	38
SB-56062	3/4 (M)	61	97	38
SB-56063	3/4 (L)	88	140	38

SB-58081	1 (S)	37	63	50
SB-58082	1 (M)	59	98	50
SB-58083	1 (L)	81	140	50