

T型螺帽
T SLOT NUT

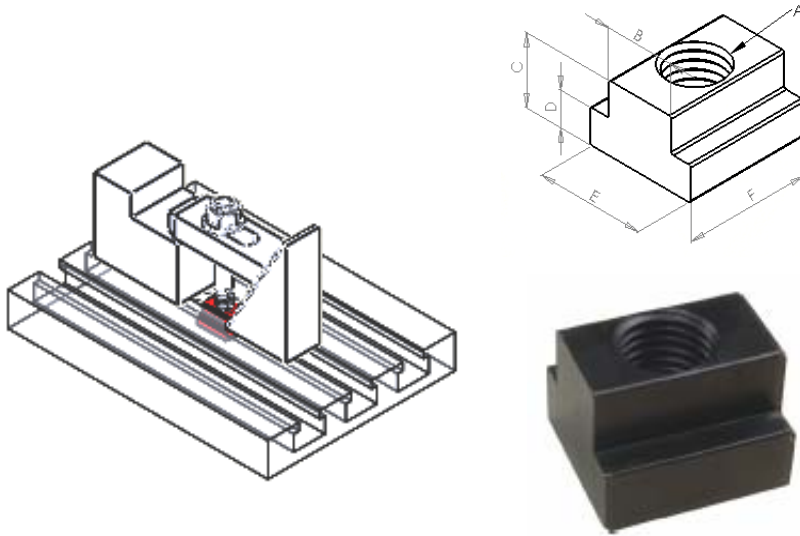

- ※ Material: S45C
- ※ Hardness of heat treatment: HRC32±5°
- ※ Surface treatment: black oxide furnished
- ※ Apply for the working table with T slot

Unit: mm

Order no.	A (Metric)	B	C	D	E	F
TNM-22021	M8X1.25	9.7	12	6	16	22
TNM-23031	M10X1.5	11.5	12	6.8	17.5	22
TNM-24041A	M12X1.75(S)	13.8	16	8	22	28
TNM-24041B	M12X1.75(M)	15.5	16	8	25	28
TNM-24041C	M12X1.75(L)	17.5	19	11	28	31
TNM-24545	M14X2.0	15.5	16	8	25	28
TNM-25051	M16XX2.0	17.5	19	11	28	31
TNM-26061	M18X2.5	19.5	24	12	32	38
TNM-27071	M20X2.5	21.7	28	14	35	38
TNM-28081	M24X3.0	27.5	36	18	44	49

Order no.	A (Inch)	B	C	D	E	F
TN-22021A	5/16"-18	9.2	12	4.5	16	22
TN-23031A	3/8"-16	10.8	12	5.5	17.5	22
TN-23031B		11.5	12	6.8	22	22
TN-23031C		13.8	16	8	22	28
TN-24041A	1/2"-12	13.8	16	8	22	28
TN-24041B		15.5	16	8	25	28
TN-24041C		17.5	19	11	28	31
TN-24042A	1/2"-13UNC	13.8	16	8	22	28
TN-24042B		15.5	16	8	25	28
TN-24042C		17.5	19	11	28	31
TN-25051A	5/8"-11	17.5	19	11	28	31
TN-25051B		18.6	19	12	31.8	31
TN-25051C		20.2	25	14	32	38
TN-26061A		20.2	25	14	32	38

TN-26061B	3/4"-10	21.7	28	14	35	38
TN-26061C		25	25	15.5	40	44.5
TN-27071A	7/8"-9	25	25	15.5	40	38
TN-28081A	1"-8	27.5	36	18	44	49